

Blowers and Fans

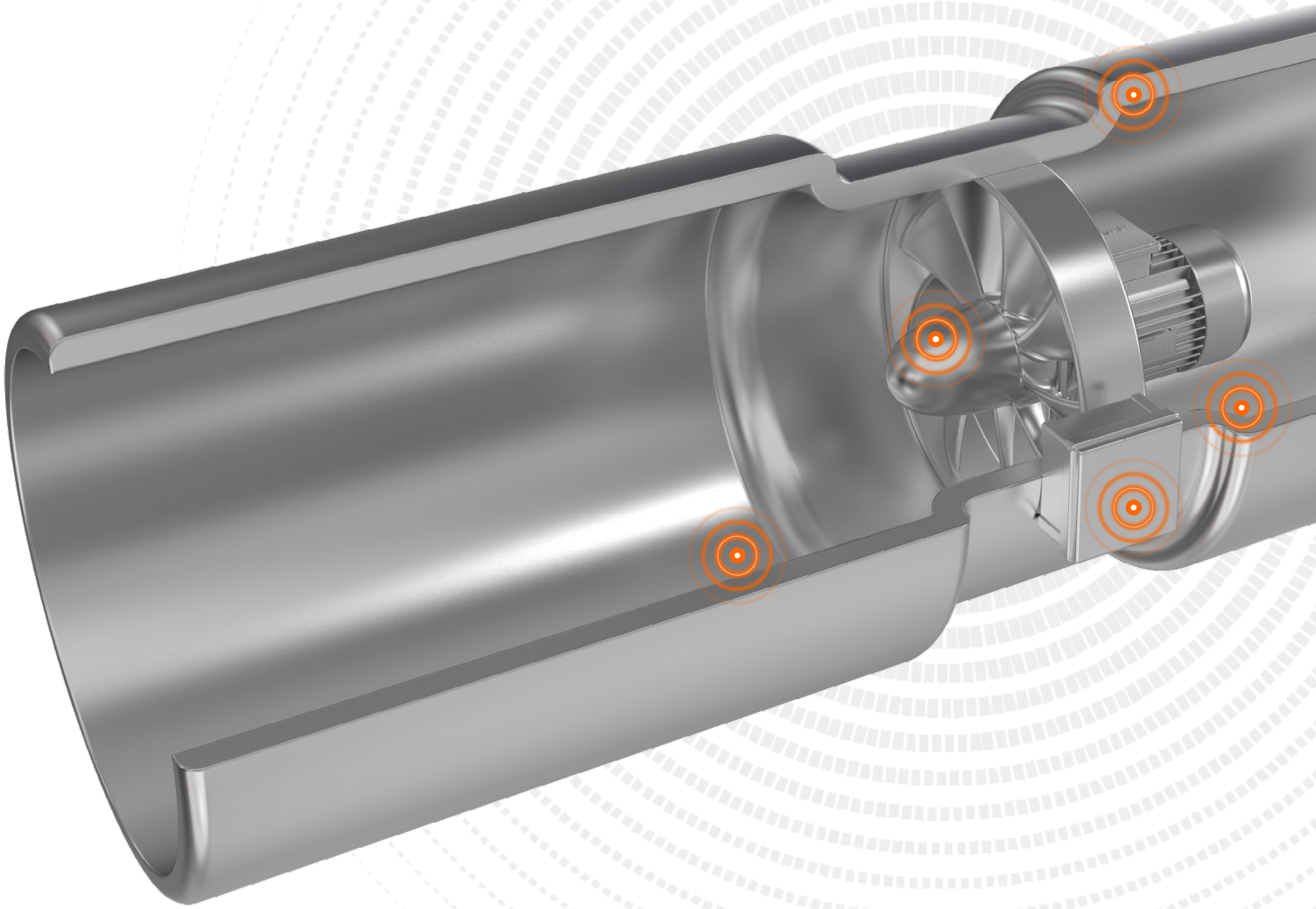

The Truly Predictive Maintenance Solution

DETECTS FAULTS
WEEKS BEFORE FAILURE

+

MORE THAN
85% ACCURATE

+

LESS THAN
ONE YEAR ROI

Built for Blowers and Fans

TruPrognostics for industrial fans is an industry-leading tool specifically built for predicting failure modes common for your blowers and fans. Novity's revolutionary TruPrognostics engine uses a carefully constructed combination of physics-based models and machine learning to detect faults at the earliest possible point in their progression and to provide an accurate estimate of the machine's remaining useful

life. Because TruPrognostics is based on physics-based models, the solution produces great results no matter what historical data you have. Get the ability to predict **loss of efficiency, bearing faults, motors faults**, and many more fault modes.

The Right Sensor for the Right Job

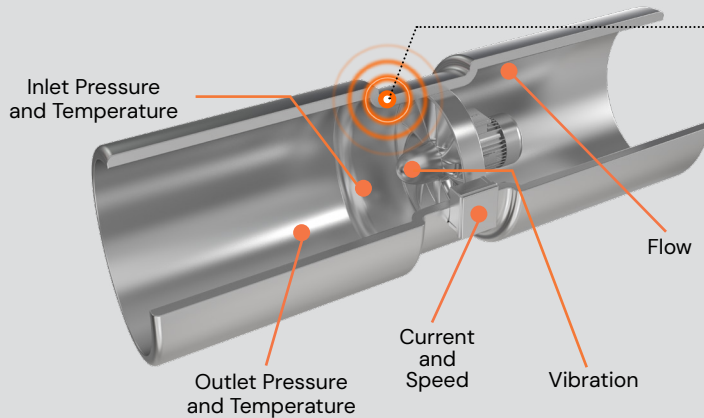

Asset-Centric Dashboards

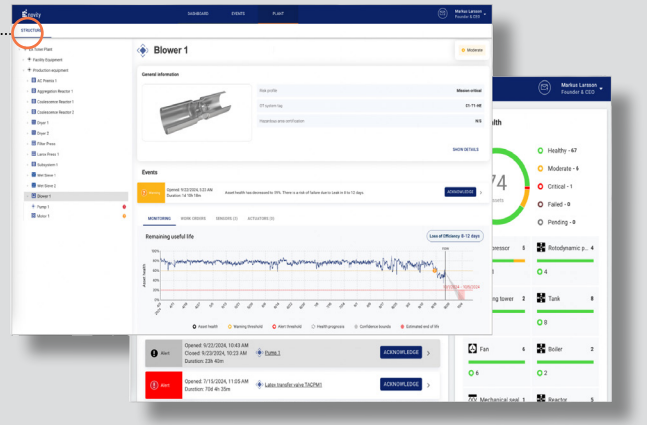

Key Features

- 24/7 Always-On Monitoring
- Integrate with your CMMS and historian
- Minimal to no added sensing hardware
- No historical data required

Value

- Over 85% Accuracy of Predictions
- Detect Faults Days Before Failure
- Fast ROI Payback Period

Reports & Notifications

- Anomaly Detections
- Fault Diagnoses
- RUL Estimates



TruPrognostics™

Our TruPrognostics engine is a truly predictive system that combines machine learning, hybrid model reasoning, and fundamental physics principles to accurately estimate the remaining useful life of critical manufacturing and production equipment even if you lack high quality historical data.

